



The nanoDAQ-LTR is a new development by Chell Instruments utilizing the latest technology in digital transducers.

The nanoDAQ-LTR is now available in 16 and 32 channel forms in an ultra-miniature slim-line package. It features a Souriau 8STA0-06-9PN connector making it very suitable for motor sport and other on-vehicle applications.

The nanoDAQ-LTR is a fully configurable smart pressure scanner that will output pressure data in engineering units over Ethernet and CAN. The data output over all interfaces is identical to the nanoDAQ-LTR's sister products; the nanoDAQ and the MicroDAQ3.

The nanoDAQ-LTR makes use of 17 or 35 absolute transducers which are thermally compensated and conditioned to provide 16 or 32 either absolute or differential measurements relative to one reference port.

The user can select a number of operating parameters using the embedded web server. These include; absolute or differential, TCP and UDP setup, data averaging and units, CAN setup and time stamp configuration.

The nanoDAQ-LTR features a hardware implementation of the IEEE 1588 PTPv2 time stamping protocol which allows the pressure data to be time stamped to a resolution of 1µSecond.

The nanoDAQ-LTR also features a hardware trigger allowing the pressure acquisition to be synchronised to an external TTL pulse.

The nanoDAQ-LTR is contained within a miniature package which is sealed to IP67 enabling it to be used in harsh environments. It is also available with alternative packaging to suit particular applications - please contact Chell for more details.

The transducers within the nanoDAQ-LTR have a very high proof pressure (50 psig or 90 psig depending on range) which reduces the chances of in-field transducer damage.

# nanoDAQ-LTR

## Digital Pressure Scanner

- **16 and 32 channel Intelligent pressure scanner module with engineering unit output.**
- **User selectable absolute or differential measurement**
- **Up to 0.02% FS accuracy output.**
- **With IEEE 1588 PTPv2 time stamping**
- **Thermally compensated from -20 to 90°C**
- **Output over Ethernet (100Mbit TCP / UDP) and CAN.**
- **Uses CAN-FD and 'classic' CAN (2.0B)**
- **Rugged enclosure for on-vehicle applications. Sealed to IP67**
- **Fully configurable over Ethernet with embedded web server.**

**General**

Ranges Available	1, 2.5, 5, 7, 10,17, 35, 55, 103, 207 and 310 kPa
Number of channels	16 / 32
Maximum Acquisition Speed (measurements / channel / second)	200

**Data Output**

Output formats	CAN and Ethernet (TCP/IP & UDP), IENA
Ethernet Specification	100Mbit TCP/IP or UDP (user configurable)
CAN Specification	'classic' CAN (2.0B) and CAN-FD (user configurable)

**Performance**

System Accuracy	See table below
Absolute Ranges	
15 to 115 kPa (2.2 to 16.8 psia) for differential ranges $\leq$ 35 kPa (5psi)	0.04% FS
13 to 160 kPa (1.885 to 23.2 psia) for differential ranges = 55 kPa (8psi)	0.04% FS
15 to 206 kPa (2.2 to 29.9 psia) for differential ranges = 103 kPa (15psi)	0.02% FS
0 to 400 kPa (2.2 to 58.01 psia) for differential ranges $\geq$ 207 kPa (30psi)	0.02% FS
Reference pressure range (differential range $\leq$ 8 psid)	13 kPa to 160 kPa (1.89 psia to 23.2 psia)
Reference pressure range (differential range $>$ 8 psid)	13 kPa to 400 kPa (1.89 psia to 58 psia)
Line pressure effect	Negligible
Proof Pressure (all ranges)	Ranges $\leq$ 8 psid :50 psig (64.5 psia), Ranges $>$ 8 psid:90 psig (105 psia)
Output Resolution	16 bit or $\pm$ range / 65536
System Resolution	24 bit

**Mechanical**

16 Channel	74 x 27 x 15.2mm excluding tubulations
32 Channel	74 x 33.5 x 16.3mm excluding tubulations
Weight (16 Channel / 32 Channel)	36g / 42g
Enclosure Sealing	IP67
Measurement ports	1.0 mm (0.04") bulged tubulations

**Power Supply**

Input supply	8-25 VDC
Power consumption	1VA Max)
Electrical Connector	Souriau 8STA0-06-9PN

**Environment**

Operating Temperature Range	-20 to +90°C
Compensated Temperature Range	20 to +90°C (optional -20 to +90°C)
Storage Temperature Range	-20 to +90°C
Ambient Pressure	100 mbar abs (52,000 ft) to 2.5 bar abs
Vibration	Engine standard vibration test to DO160E category S, curve W with duration of 1 hr/axis. Fan blade (20 g 2 kHz)
Shock	Fan blade out to DO160F section 7 (40g 11 m/s)

**Timing / Data Synchronisation**

Time Stamping	IEEE 1588 PTPv2
Time Stamping Resolution	1 $\mu$ s
Hardware Trigger	5 V TTL pulse, maximum 200 Hz, minimum 2 Hz

## nanoDAQ-LTR Performance

\* Measurement uncertainty includes all non-linearity, repeatability and thermal gain errors over the compensated temperature range. Differential range assumes a reference pressure of 1 bar.

Differential Range (+/-)	Standard	Output Resolution (Pa)	Measurement Uncertainty*		
			Deviation (Pa)	%FS	
1 kPa	4" water	0.03	5	20	2%
2.5 kPa	10" water	0.08	5	20	0.8%
5 kPa	20" water	0.15	5	20	0.4%
7 kPa	1 psi	0.21	5	20	0.3%
10 kPa	1.5 psi	0.31	5	20	0.2%
17 kPa	2.5 psi	0.52	5	20	0.1%
35 kPa	5 psi	1	7	20	0.06%
55 kPa	8 psi	1.7	7	20	0.04%
-83 kPa to 103 kPa	-12 to 15 psi	3.15	15	50	0.05%
-83 kPa to 207 kPa	-12 to 30 psi	6.3	18	70	0.03%
-83 kPa to 300 kPa	-12 to 43 psi	9.5	20	100	0.03%

## Dimensions

### 16-Channel

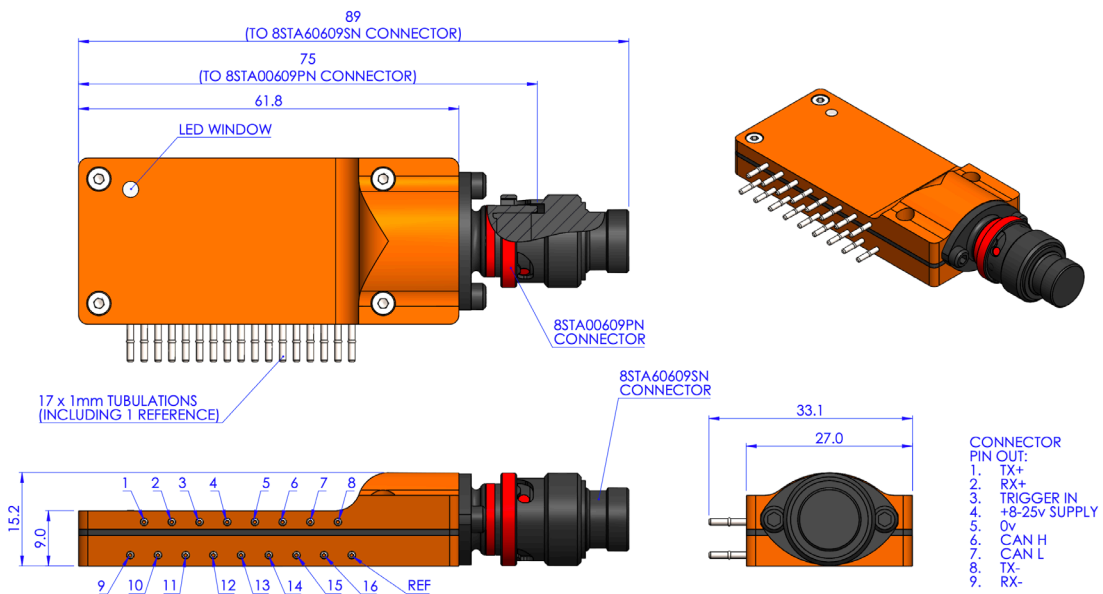

### 32-Channel

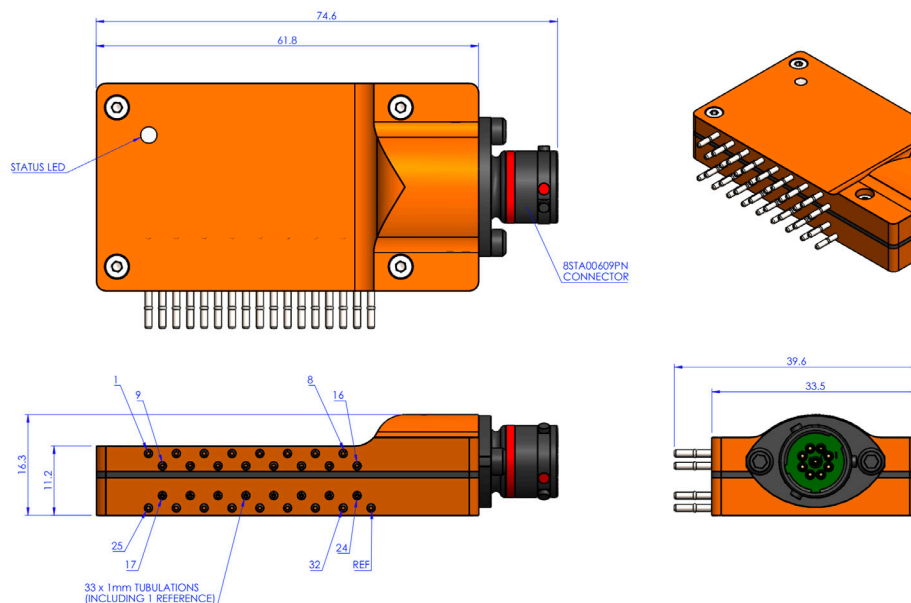

## Part Number:

16LTR -AABB - 16 channel

32LTR -AABB - 32 channel

---

### AA = Range

01 = 1 kPa (4" water)  
02 = 2.5 kPa (10" water)  
03 = 5 kPa (20" water)  
04 = 7 kPa (1 psi)  
05 = 10 kPa (1.5 psi)  
06 = 17 kPa (2.5 psi)  
07 = 35 kPa (5 psi)  
08 = 55 kPa (8 psi)  
09 = 103 kPa (15 psi)  
10 = 207 kPa (30 psi)  
11 = 310 kPa (45 psi)

### BB = Calibrated Temperature Range

01 = 20 to 100°C  
02 = -20 to 100°C