



flightDAQ3

32 Channel Advanced Pressure Scanner

- New and advanced use of digital sensor technology.
- Optional iDDS interface
- Unparalleled Data Quality: up to 0.02% of full scale
- High speed : 400Hz per channel
- Absolute and differential measurements
- Electrically driven valve for purge and re-zero
- Power-over-Ethernet
- Complete with IEEE 1588 PTPv2 time stamping
- Internal Heaters for use down to -40°C
- 24 bit ADC per channel
- Output over Ethernet (100Mbit TCP/IP / UDP), Chell native protocol, Netscanner protocol, iDDS and IENA
- Quick disconnect measurement couplings
- Fully configurable over Ethernet with embedded web server

The Chell flightDAQ3 is another step forward in Chell's long line of pressure scanners optimised for test cell and flight use. The flightDAQ3 makes use of high accuracy digital absolute transducers to give unparalleled performance - even in the most demanding environments.

The flightDAQ3 will output differential or absolute temperature compensated engineering unit pressure data over Ethernet with the Chell native protocol, IENA, and iDDS at speeds up to 400Hz per channel. It also features a Netscanner emulation mode where a subset of the Netscanner commands are supported.

The flightDAQ3 incorporates an electrically driven shuttle valve for purge and re-zero - therefore removing the need for high pressure supply lines associated with previous versions. The shuttle valve features positional feedback, current sensing on the motor and a count of the number of shuttles to help with planning maintenance requirements. The valve life is tested to 10,000 cycles.

For cold applications, it has an in-built heater to maintain valve operation at cold temperatures. The power of the heater can be selected to cope with different power supply scenarios. In addition, there is an internal purge control valve to switch the purge gas on and to vent it before the valve is returned to run.

External measurement connectors are made with the Chell SQDC range which are durable, high temperature quick disconnects. These are compatible with both flexible and solid tubes. The calibration, reference and purge connections are via 5/16-24 SAE 'O' ring boss which can be fitted with Swagelok® or Chell AS series quick disconnects.

The flightDAQ3 has a smart power supply which is compatible with a DC supply and PoE. The flightDAQ3 will always use a DC supply if it senses one - otherwise it will negotiate with a PoE enabled switch for power.

With the addition of an iDDS run time license, the flightDAQ3 is fully compatible with iDDS installations.

General	
Differential ranges available	1, 2.5, 5, 7, 10,17, 35, 55, 103, 207, 310, 689 and 1034 kPa
Number of channels	32
Maximum acquisition speed (measurements / channel / second)	400 (200 for iDDS output)
Data Output	
Output types	Ethernet (TCP/IP & UDP), Chell and Netscanner protocols, IENA and iDDS (optional)
Ethernet Specification	100Mbit TCP/IP or UDP (user configurable)
Performance	
System Accuracy	See table below
Absolute Ranges	160 kPa, 400 kPa and 1140 kPa
Calibrated absolute pressure range for differential range ≤ 55 kPa (8 psid)	0.5 kPa to 160 kPa (0.07 psia to 23.2 psia)
Calibrated absolute pressure range for differential ranges between 103 kPa (15 psi) and 300 kPa (43.5 psid)	0.5 kPa to 400 kPa (0.07 psia to 58 psia)
Calibrated absolute pressure range for differential range ≥ 689 kPa (100 psid)	14 kPa to 1140 kPa (2 psia to 165 psia)
Line pressure effect	Negligible
Proof Pressure	Ranges ≤ 8 psid :50 psig (64.5 psia), Ranges >8 psid:90 psig (105 psia)
Output Resolution	16 bit or ±range / 65536
System Resolution	24 bit
Mechanical	
Dimensions (width x depth x height in mm)	241 x 89 x 115 excluding mating SQDC
Weight (Valved / non-valved)	2 kg
Enclosure Sealing	IP54
Measurement ports	1.0mm or 1.6mm bulged tubulations, 1mm or 1/16" solid tubing - all via mating SQDC
Purge, cal and reference ports	5/16"-24 SAE O ring boss
Maximum purge pressure	7 bar gauge
Purge Flow	22 SLPM at 1 bar purge, 46 SLPM at 2 bar purge and 66 SLPM at 3 bar purge
Power Supply	
DC Power	18 to 32 VDC (abs max 60 VDC) with smart sensing power supply max current = 1.25A at 28VDC
PoE Specification	IEEE 802.3at (Type 2) and IEEE 802.3bt (Type 3)
Electrical Connector	09-49-15KPT06FS or TV06ZN-11-35PN-UWBSB2
Environment	
Operating Temperature Range	-40 to +90°C
Compensated Temperature Range	-40 to +90°C with heaters enabled
Storage Temperature Range	-55 to +90°C
Ambient Pressure	100 mbar abs (52,000 ft) to 2.5 bar abs
Vibration	Engine standard vibration test to DO160E category S, curve W with duration of 1 hr/axis. Fan blade (20 g 2 kHz)
Shock	Fan blade out to DO160F section 7 (40g 11 m/s)
Maximum relative humidity	95% at 50°C (non-condensing)
Radiated emissions	MIL standard 461-E: RE102
Conducted emissions	MIL standard 461-E/MIL standard 461-C
Timing / Data Synchronisation	
Time Stamping	IEEE 1588 PTPv2
Time Stamping Resolution	1µs
Hardware Trigger	5 V TTL pulse, maximum 400 Hz, minimum 2 Hz

flightDAQ3 Accuracy - A Metrology Approach

The performance and flexibility of the 2432 calls for a detailed and transparent approach to specifying its accuracy. The table below details the resolution, standard deviation and errors with 95% confidence (2 x sigma). The error figure below includes all the contributions from:

- Limit of accuracy (linearity)
- Repeatability
- Stability (noise)
- Long term drift (12 months)
- Thermal errors from 0 to 90°C (see notes on 689 and 1034 kPa ranges)
- Resolution limitations
- Line pressure effects

For more details on how the performance specifications are derived, please see our application notes on the subject.

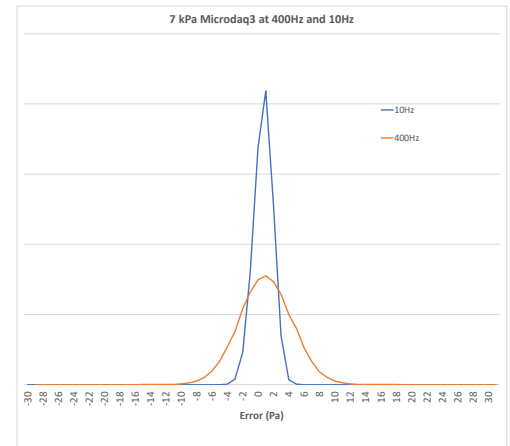

Differential Ranges

Differential Range (+/-) ¹	Max Absolute Range ²	Output Resolution (Pa)	Standard Deviation (Pa) ³	Error (95% Confidence)		
				±Pa	%FS ⁴	
1 kPa	4" water	0.5 to 175kPa	0.03	0.91	1.82	0.2%
2.5 kPa	10" water	0.5 to 175kPa	0.08	0.91	1.82	0.07%
5 kPa	20" water	0.5 to 175kPa	0.15	0.91	1.82	0.04%
7 kPa	1 psi	0.5 to 175kPa	0.21	1.1	2.26	0.03%
10 kPa	1.5 psi	0.5 to 175kPa	0.31	1.25	2.5	0.03%
17 kPa	2.5 psi	0.5 to 175kPa	0.52	1.5	3.0	0.02%
35 kPa	5 psi	0.5 to 175kPa	1	2.01	7.0	0.02%
55 kPa	8 psi	0.5 to 175kPa	1.7	1.71	11	0.02%
-83 kPa to 103 kPa	-12 to 15 psi	0.5 to 400 kPa	3.15	3.0	20	0.02%
-83 kPa to 207 kPa	-12 to 30 psi	0.5 to 400 kPa	6.3	5	40	0.02%
-83 kPa to 300k Pa	-12 to 43.5 psi	0.5 to 400 kPa	9.5	9.0	60	0.02%
-83 kPa to 689 kPa ⁴	-12 to 100 psi	14 kPa to 1.14 MPa	21	16	400	0.06%⁵
-83 kPa to 1034 kPa ⁴	-12 to 150 psi	14 kPa to 1.14 MPa	30	18	600	0.06%⁵

1) Differential range assumes a reference of 1 bar. Reference pressure can vary as long as all measurements are within the Max Absolute Range² of the transducers.
 2) Max absolute range of the transducers.
 3) Data collected at 100Hz with an average of 16.
 4) %FS values refer to the percentage of the differential range as listed. See above for error definition.
 5) Error up to 70°C, ±0.1%FS between 70°C and 90°C

Absolute Ranges

Absolute Range	Output Resolution (Pa)	Standard Deviation (Pa) ¹	Error (95% Confidence)		
			±Pa	%FS ²	
Absolute range for differential ranges up to 55 kPa (8 psi)					
0.5 to 160 kPa	0.07 psia to 23.2 psia	2.24 ³	1.6	30	0.02%
Absolute range for differential ranges of 103, 207 and 300 kPa (15, 30 and 43.5 psi)					
0.5 to 400 kPa	0.07 psia to 58.01 psia	6.1 ³	6	60	0.02%
Absolute range for differential ranges of 689 and 1034 kPa (100 and 150 psi)					
14 to 1140 Kpa	2 to 165 psia	17	20	1000	0.1%⁴

1) Data collected in accuracy mode with an average of 16
 2) %FS values refer to the percentage of the maximum absolute values as listed.
 3) Absolute range can be user configured to improve resolution.
 4) Error up to 70°C, ±0.15%FS between 70°C and 90°C

Digital Transducers - A revolution in data quality

The digital transducers used in the flightDAQ3 provide unparalleled data quality. When the pressure and temperature output for each transducer are processed with our proprietary thermal compensation routine, the results set a new standard for pressure scanners and a considerable improvement over the flightDAQ2 product range.

The histogram opposite shows a 15 psid flightDAQ3 when compared to the data from a flightDAQ2 which incorporate a digitally thermal compensated scanner using conventional transducers.

This performance removes the need for on-line calibration and, in most cases, rezero.

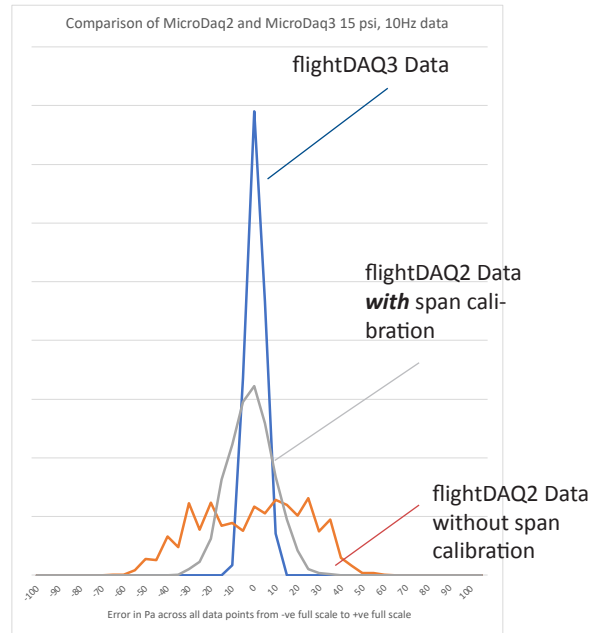

FlightDaq3 Pneumatic Layout - Run Mode

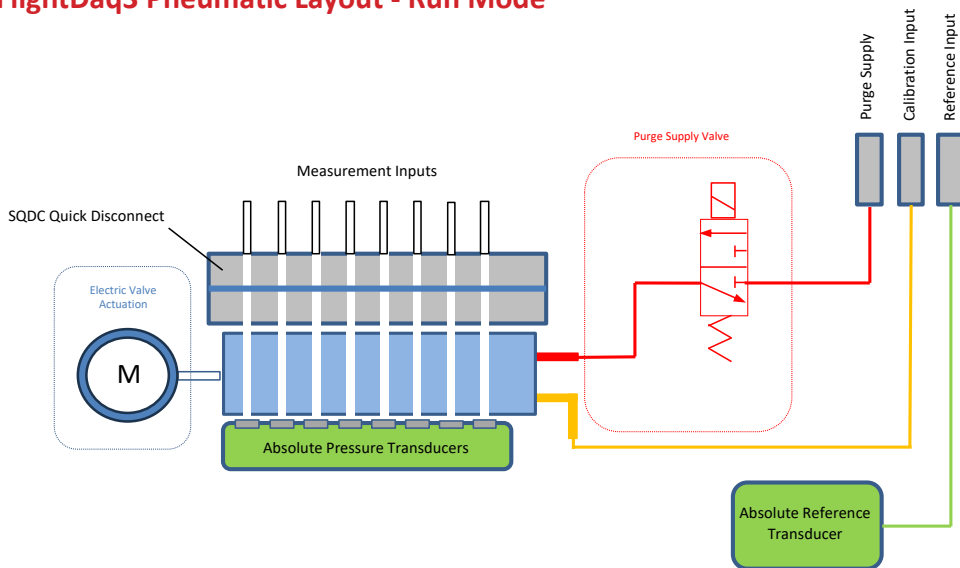

FlightDaq3 Pneumatic Layout - Purge Mode

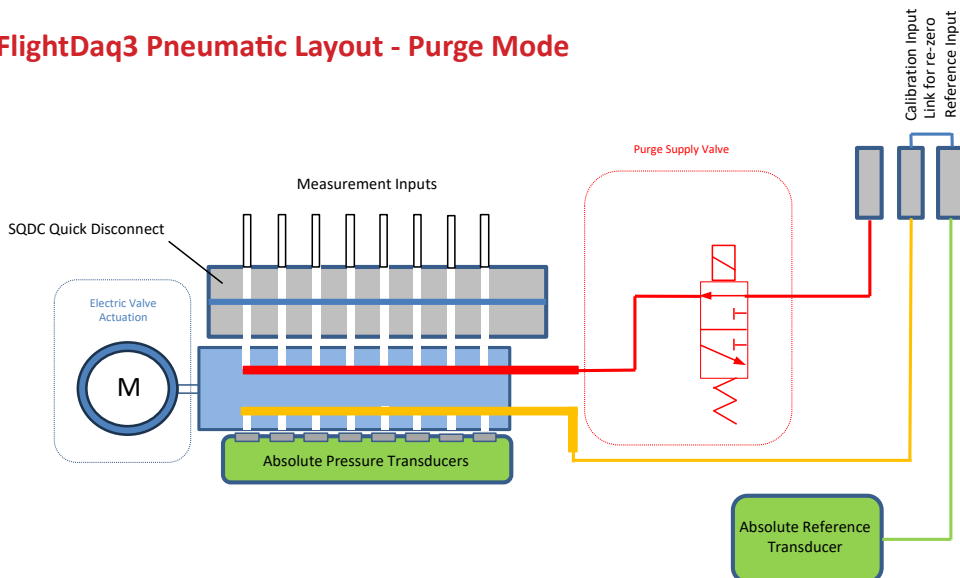

flightDAQ3 Dimensions

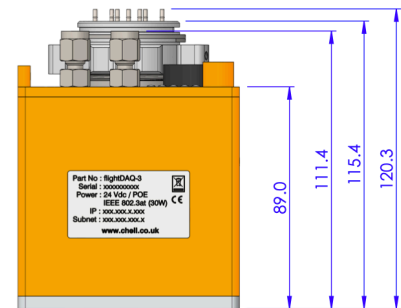
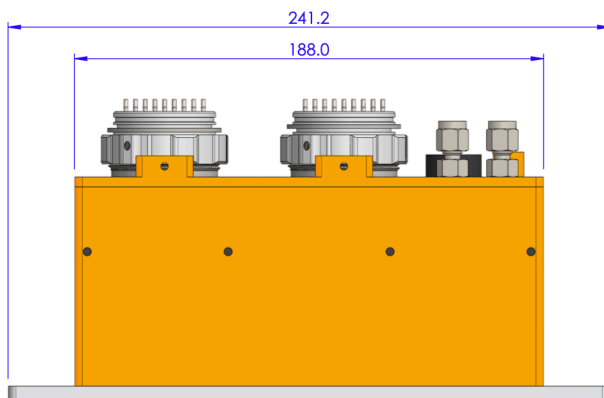
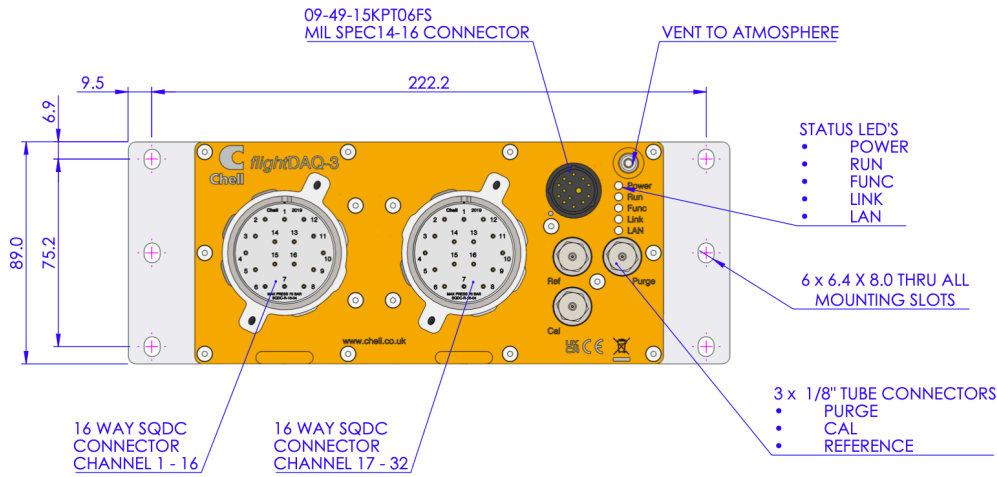

Part Number:

32FD3 -AABBCCDDEE

AA = Range

- 01 = 1 kPa (4" water)
- 02 = 2.5 kPa (10" water)
- 03 = 5 kPa (20" water)
- 04 = 7 kPa (1 psi)
- 05 = 10 kPa (1.5 psi)
- 06 = 17 kPa (2.5 psi)
- 07 = 35 kPa (5 psi)
- 08 = 55 kPa (8 psi)
- 09 = 103 kPa (15 psi)
- 10 = 207 kPa (30 psi)
- 11 = 310 kPa (43. psi)
- 12 = 689 kPa (100 psi)
- 13 = 1034 kPa (150 psi)

BB = Measurement Ports

- 00 = No mating Connector (blanks only)
- 01 = AQDC 1.0mm (0.040") bulged tubulations
- 02 = AQDC 1.6mm (0.040") bulged tubulations
- 03 = AQDC 1.0mm compression fittings
- 04 = AQDC 1/16" compression fittings (with Gyrolok® ferrule pairs)
- 05 = SQDC 1.0mm (0.040") bulged tubulations
- 06 = SQDC 1.6mm (0.040") bulged tubulations
- 07 = SQDC 1.0mm compression fittings
- 08 = SQDC 1/16" compression fittings (with Gyrolok® ferrule pairs)

EE = Interface Types

- 01 = Chell Interface, IENA and NetScanner emulation
- 02 = Chell Interface, IENA, NetScanner emulation and DDS
- 03 = Chell interface, IENA, NetScanner emulation and DDS (including iDDS run time license).

DD = Service ports

- 01 = 5/16" - SAE O-ring boss
- 02 = 1/8" Swagelok®
- 03 = AS205 quick disconnect

CC = Interface / Supply

- 01 = 09-49-15KPT06FS
- 02 = TV06ZN-11-35PN-UWBSB2