

## microCAT3

### 64 Channel EtherCAT Pressure Scanner

- **EtherCAT based scanning solution.**
- **Unparalleled Data Quality: up to 0.02% of full scale**
- **High speed : 400Hz per channel**
- **Absolute and differential measurements**
- **Optional electrically driven valve for purge and re-zero**
- **Thermally compensated from 0 to 90°C (-20 to 90°C optional).**
- **24 bit ADC per channel**
- **Output over EtherCAT and CAN (2.0B and CAN-FD)**
- **Available with quick-disconnect top plate**
- **Fully configurable over Ethernet with embedded web server**

The Chell microCAT3 is an EtherCAT version of the class leading Ethernet based microDAQ3 product range. It uses the same high accuracy digital sensors combined with an advanced processor design which results in the most accurate pressure scanner on the market.

EtherCAT is a specific interfaced which is based on Ethernet but with the following advantages:

- Increased bandwidth. EtherCAT is many times more efficient than Ethernet making the acquisition of high speed data from multiple units more straight forward.
- Non-vendor specific protocol. As the microCAT adheres to the EtherCAT standard, no special code needs to be written in order to interface with it.
- Integrated time stamping. The EtherCAT protocol includes a distributed clock that time stamps the data.
- Network topology independent. EtherCAT is insensitive to network topology and the units are designed to be daisy-chained in loop or star configuration.

The microCAT3 offers the option of an electrically driven valve that gives the scanner a purge and re-zero facility. The valve has been years in development and features precise positional measurement and current monitoring to ensure reliability.

The microCAT3 is also the smallest digital pressure scanner on the market - even when fitted with the electrically driven valve. The non-valved option gives the user a further reduction in size when purge is not required.

The microCAT3 makes use of high accuracy transducers which are combined with two 24-bit ADC's per port - one for pressure and one for temperature. This precise temperature measurement allows the MicroCAT3 to almost entirely compensate for thermal effects over its wide operating range.

**General**

Differential ranges available	1, 2.5, 5, 7, 10,17, 35, 55, 103, 207, 310, 689 and 1034 kPa
Number of channels	64
Maximum Acquisition Speed (measurements / channel / second)	400 (200Hz for 689 and 1034 kPa ranges)

**Data Output**

DC Powered version (CC=02)	EtherCAT and CAN
Ethernet Specification (for webserver configuration)	100Mbit TCP/IP
CAN Specification	CAN-FD and 2.0B

**Performance**

System Accuracy	See table below
Absolute Ranges	160 kPa, 400 kPa and 1140 kPa
Calibrated absolute pressure range for differential range $\leq$ 55 kPa (8 psid)	14 kPa to 160 kPa (2.0 psia to 23.2 psia)
Calibrated absolute pressure range for differential ranges between 103 kPa (15 psi) and 300 kPa (43.5 psid)	14 kPa to 400 kPa (2.0 psia to 58 psia)
Calibrated absolute pressure range for differential range $\geq$ 689 kPa (100 psid)	13 kPa to 1140 kPa (1.89 psia to 165 psia)
Line pressure limitation	None - as long as all measured pressures are within above pressures
Proof Pressure (all ranges)	Ranges $\leq$ 55 kPa : 35 kPa (50 psig), Ranges $>$ 55 kPa : 1380 kPa (200 psig)
Output Resolution	16 bit or $\pm$ range / 65536
System Resolution	24 bit

**Mechanical**

Valved version Dimensions width x depth x height in mm)	85 x 39 x 34 excluding tubulations
Non-valved version Dimensions (width x depth x height in mm)	85 x 39 x 34 excluding tubulations (with reduced height section)
Weight (Valved / non-valved)	205g / 157g
Enclosure Sealing	IP54
Measurement ports	1.0 mm (0.04") bulged tubulations
Purge ports (valved version only)	2.3 mm (0.09") bulged tubulation
Maximum purge pressure	7 bar gauge
Purge Flow	22 SLPM at 1 bar purge, 46 SLPM at 2 bar purge and 66 SLPM at 3 bar

**Power Supply**

Input supply	8-30 VDC
Power consumption	1W (non-valved), 4W (valved)
Electrical Connector (DC Powered version)	Female 15-way micro-miniature 'D' type MWDM2L-15SSB (suggested mate : Glenair MWDM2L-15PS - solder cup version)

**Note :** On order to minimise the package size, the 15 way connector serves as both the EtherCAT input and output (see pin-out with drawings). The embedded webserver can also be accessed via this connector. The microCAT3 will boot up in Ethernet mode to facilitate this if pins 10 and 11 are shorted together during power-up. Chell can provide all necessary cables - please contact us for further details.

**Environment**

Operating Temperature Range	-40 to +90°C
Compensated Temperature Range	0 to +90°C (optional -20 to +90°C)
Storage Temperature Range	-40 to +90°C
Ambient Pressure	5 mbar abs to 2.5 bar abs
Vibration	Engine standard vibration test to DO160E category S, curve W with duration of 1 hr/axis. Fan blade (20 g 2 kHz)
Shock	Fan blade out to DO160F section 7 (40g 11 m/s)
Maximum relative humidity	95% at 50°C (non-condensing)

**Timing / Data Synchronisation**

Contained within the EtherCAT protocol
--

## microCAT3 Accuracy - A Metrology Approach

The performance and flexibility of the microCAT3 calls for a different approach to specifying its accuracy. The table below details the resolution, standard deviation and errors with 95% confidence (2 x sigma). This is comparable with data from other manufacturers.

In addition to this, we have detailed the measurement uncertainty which takes into account the following sources of error:

- Uncertainty of the Chell calibration standards used in production
- Thermal errors from 0 to 90°C
- Drift errors over 12 months

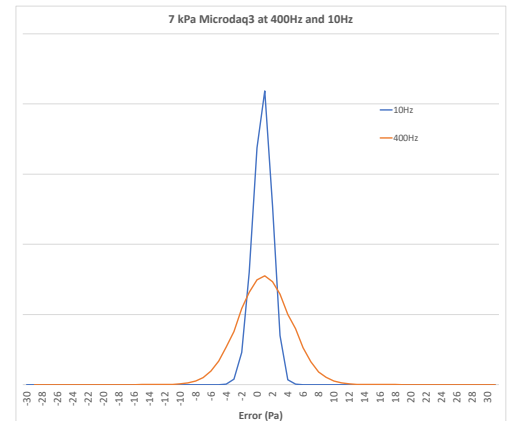

Differential Range (+/-) <sup>1</sup>	Output Resolution (Pa)	Standard Deviation (Pa) <sup>3</sup>	Error (95% Confidence)		Uncertainty
			±Pa	%FS <sup>2</sup>	%FS <sup>2</sup>
1 kPa	4" water	0.03	0.91	1.82	<b>0.2%</b> 0.4%
2.5 kPa	10" water	0.08	0.91	1.82	<b>0.07%</b> 0.15%
5 kPa	20" water	0.15	0.91	1.82	<b>0.04%</b> 0.08%
7 kPa	1 psi	0.21	1.1	2.26	<b>0.03%</b> 0.06%
10 kPa	1.5 psi	0.31	1.25	2.5	<b>0.03%</b> 0.04%
17 kPa	2.5 psi	0.52	1.5	3.0	<b>0.02%</b> 0.03%
35 kPa	5 psi	1	2.01	7.0	<b>0.02%</b> 0.03%
55 kPa	8 psi	1.7	1.71	11	<b>0.02%</b> 0.03%
-83 kPa to 103 kPa	-12 to 15 psi	3.15	3.0	20	<b>0.02%</b> 0.03%
-83 kPa to 207 kPa	-12 to 30 psi	6.3	5	40	<b>0.02%</b> 0.03%
-83 kPa to 300k Pa	-12 to 43.5 psi	9.5	9.0	60	<b>0.02%</b> 0.03%
-83 kPa to 689 kPa <sup>4</sup>	-12 to 100 psi	21	100	300	<b>0.04%</b> 0.05%
-83 kPa to 1034 kPa <sup>4</sup>	-12 to 150 psi	30	150	400	<b>0.04%</b> 0.05%

1) Differential range assumes a reference of 1 bar. Reference pressure can vary as long as all measurements are within the absolute range of the transducers.  
 2) %FS values refer to the percentage of the differential range as listed.

3) Data collected in accuracy mode with an average of 16.  
 4) Provisional

Absolute Range	Output Resolution (Pa)	Standard Deviation (Pa) <sup>1</sup>	Error (95% Confidence)		Uncertainty
			±Pa	%FS <sup>2</sup>	%FS <sup>2</sup>
<b>Absolute range for differential ranges up to 35 kPa (5 psi)</b>					
15 <sup>3</sup> to 115 kPa	2.2 psia to 16.8 psia	1.5	1.13	20	<b>0.02%</b> 0.025%
<b>Absolute range for differential range of 55 kPa (8 psi)</b>					
13.0 <sup>3</sup> to 160 kPa	1.885 psia to 23.2 psia	2.24	1.6	30	<b>0.02%</b> 0.025%
<b>Absolute range for differential range of 103 kPa (15 psi)</b>					
15.0 <sup>4</sup> to 206 kPa	2.2 psia to 29.9 psia	2.9	3.5	40	<b>0.02%</b> 0.025%
<b>Absolute range for differential range of 207 and 300 kPa (30 and 43.5 psi)</b>					
0 <sup>4</sup> to 400 kPa	0 psia to 58.01 psia	6.1	6	60	<b>0.02%</b> 0.025%
<b>Absolute range for differential range of 689 and 1034 kPa (100 and 150 psi)<sup>7</sup></b>					
0 <sup>6</sup> to 1140 kPa	0 psia to 165 psia	17	400	1000	<b>0.08%</b> 0.1%

1) Data collected in accuracy mode with an average of 16  
 2) %FS values refer to the percentage of the maximum absolute values as listed.  
 3) Lowest measurable absolute pressure for ranges up to 160kPa is 11kPa.  
 4) Lowest measurable absolute pressure for 206 and 400 kPa range ranges is 0.5kPa.

5) Lowest absolute calibrated pressure is 14 kPa as standard (please contact us for lower pressures)  
 6) Lowest measurable absolute pressure for 1140kPa range is 11kPa.  
 7) Provisional

## Absolute Transducers - More information and better performance

The microCAT3 is available with two ranges of absolute sensors; 160kPa and 400 kPa absolute which are used for both the measurement and reference ports. The microCAT3s are calibrated over their full absolute range (see above) and the absolute output can be configured to suit the use case to optimise the resolution of the 16-bit output.

For differential outputs, the two reference ports (they can be used individually or averaged together) are subtracted from the measurement ports to provide a differential output. The microCAT3's are purchased pre-configured for a particular differential range to maximise the resolution of the 16-bit output. Line pressures can be accommodated as long as the range of pressures measured falls within the absolute range of the sensors.

The use of absolute transducers in the microCAT3 leads to several advantages:

- The ability for the user to switch between differential and absolute measurements.
- Unparalleled differential and absolute measurement performance.
- The ability to output differential measurements **and** the absolute value of the reference removing the need for external barometric transducers.
- The option to output absolute values for all channels and thereby removing the need for a reference all together.
- The lack of an internal reference cavity (and therefore volume) means the scanner responds much faster to changes in reference pressure (for example, changes in altitude) improving data quality.

## Digital Transducers - A revolution in data quality

The digital transducers used in the microCAT3 provide unparalleled data quality. When the pressure and temperature output for each transducer are processed with our proprietary thermal compensation routine, the results set a new standard for pressure scanners and a considerable improvement over the microDAQ2 product range.

The histogram opposite shows a 15 psid microCAT3 when compared to the data from a microCAT2 which incorporate a digitally thermally compensated (DTC) scanner using conventional analogue transducers.

The microCAT3 produces superior data to conventional compensated scanners - even when the older scanners are used with on-line calibration!

This performance removes the need for on-line calibration and, in most cases, rezero.

## The Purge Valve

We have been developing the new purge valve for the last few years. To remove the need to supply pneumatic pressures to the scanner, the new valve is electrically driven by a precision high-torque motor and gearbox. The valve is controlled to a position (measured to 5  $\mu\text{m}$ ) and the current consumed by the motor to ensure reliable, repeatable performance.

The valve has been rigorously tested to 10,000 cycles and features a cycle count so that any necessary maintenance can be planned.

The purge flow through the valve has been characterised over a pressure range (see table above) and provides a greater flow than scanners offered elsewhere.

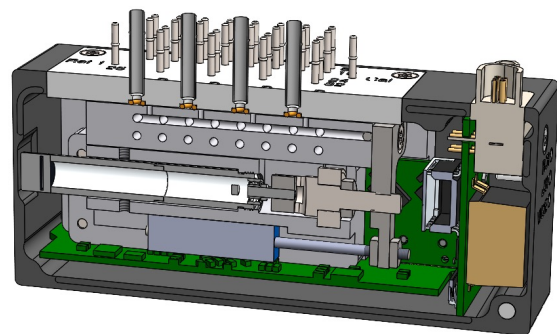
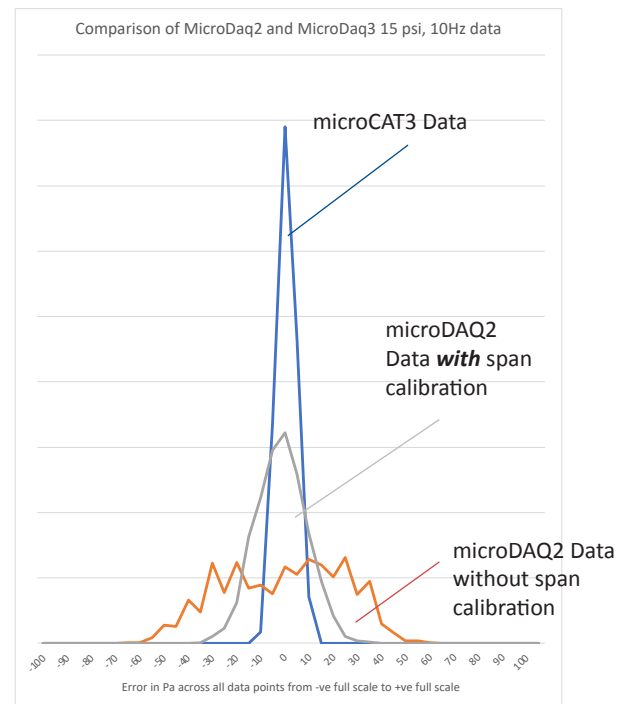

## Dimensions - Valved Version (BB=01)

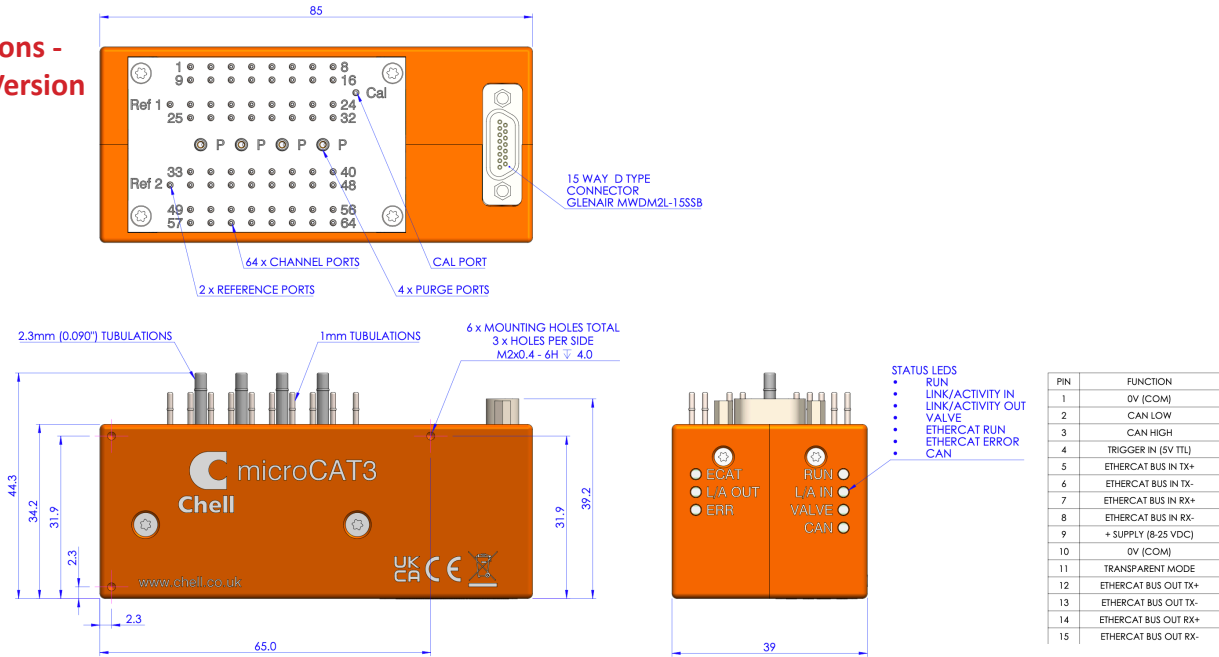

## Dimensions - Non-Valved Version (BB=02)

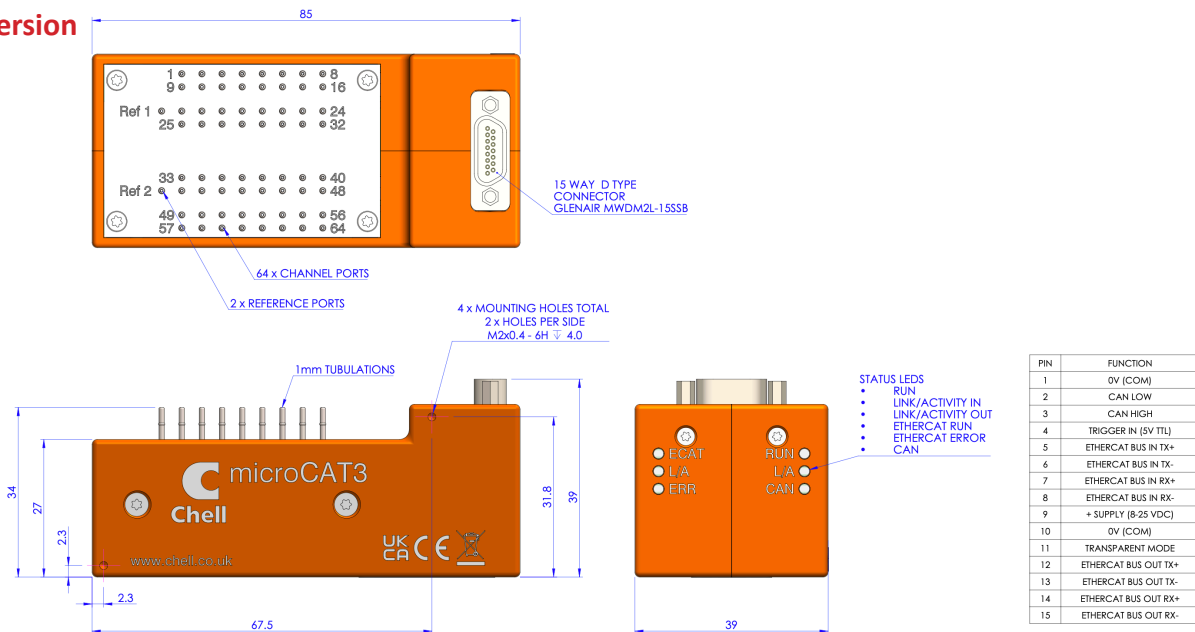

### Part Number:

64MC3 -AABBCCDD

#### AA = Range

- 01 = 1 kPa (4" water)
- 02 = 2.5 kPa (10" water)
- 03 = 5 kPa (20" water)
- 04 = 7 kPa (1 psi)
- 05 = 10 kPa (1.5 psi)
- 06 = 17 kPa (2.5 psi)
- 07 = 35 kPa (5 psi)
- 08 = 55 kPa (8 psi)
- 09 = 103 kPa (15 psi)
- 10 = 207 kPa (30 psi)
- 11 = 310 kPa (45 psi)

#### BB = Valve

- 01 = With valve and 1 mm tubulations (2.3 mm for purge tubulations)
- 02 = Without valve and 1 mm tubulations
- 03 = With valve and quick disconnect top plate
- 04 = Without valve and quick disconnect top plate
- 05 = With valve and quick disconnect intermediate plate and protector only
- 06 = Without valve and quick disconnect intermediate plate and protector only

#### DD = Calibrated Temperature Range

- 01 = 0 to 90°C
- 02 = -20 to 90°C

#### CC = Interface / Supply

- 02 = DC supply with CAN



## The Quick Disconnect Option

Both the valved and non-valved versions of the microCAT3 are available with a quick disconnect option. Here the tubulation plate is removable and can be easily exchanged for another meaning the scanner can be moved between distinct sets of tubing.

The quick disconnect options comes as a set of four plates (intermediate, tubulation and 2 x protector plates). Additional tubulation plates and protector plates can be ordered individually.

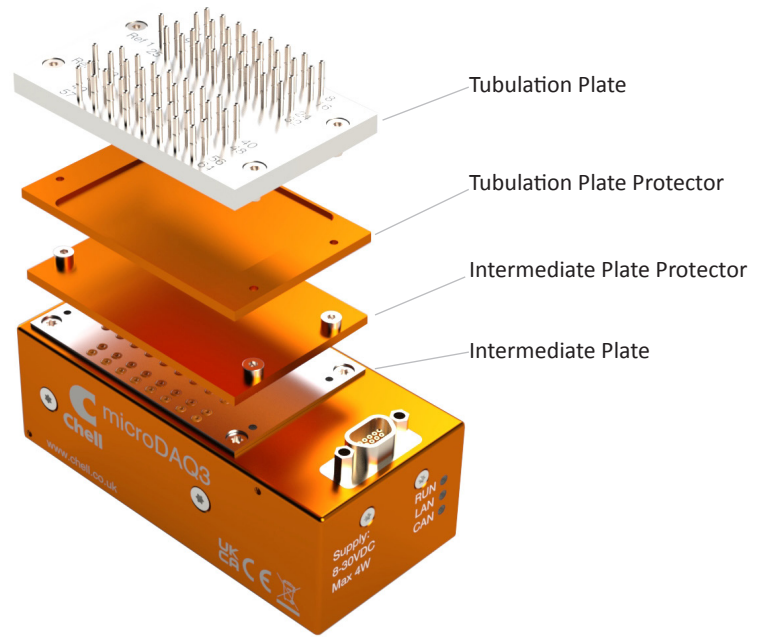

## Dimensions - Valved Version with QDC Option (BB=03)

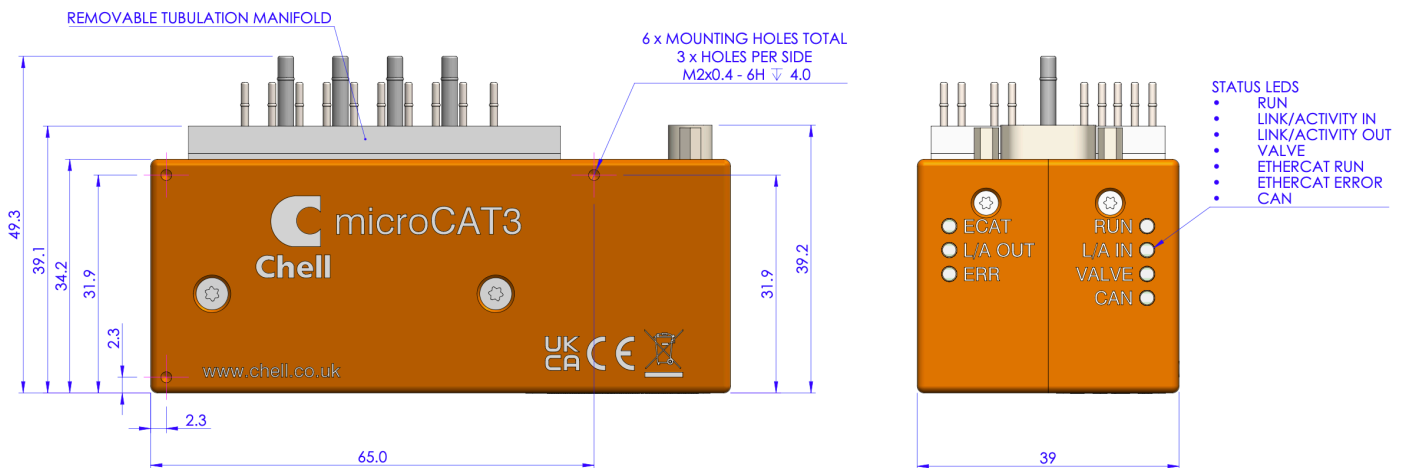

## Dimensions - Non-Valved Version with QDC Option (BB=04)

